

Effects of Even-Order Terms on Behavior Model of Envelope Tracking Transmitters

Junghwan Moon ^{#1}, Juyeon Lee, Junghwan Son, Jungjoon Kim,
Seunghoon Jee, Seungchan Kim, and Bumman Kim ^{#2}

[#]Department of Electrical Engineering and Division of Information Technology Convergence Engineering,
Pohang University of Science and Technology (POSTECH),
San 31, Hyoja-dong, Nam-gu, Pohang, Gyeongbuk, 790-784, Republic of Korea
Tel : +82-54-279-5584, Fax : +82-54-279-8115

¹jhmoon@postech.ac.kr

²bmkim@postech.ac.kr

Abstract—In the envelope tracking (ET) transmitters, the supply voltage is modulated according to the power levels for high efficiency. Such an operation generates quite different nonlinear characteristic in comparison with the conventional standalone power amplifiers (PAs). The effects of even-order nonlinear terms on ET transmitters are explored for the behavior model and digital predistortion technique. By including the even-order terms, the modeling accuracy of ET PA are significantly improved, especially for memory effect. To demonstrate the improved accuracy for the nonlinear prediction of the ET transmitter, the indirect learning based Enhanced Hammerstein predistorter is employed to compensate the transmitter. For the long term evolution signal with 10-MHz bandwidth and 6.5-dB peak-to-average power ratio, the predistorter including the even-order terms delivers a significantly better linearization result than the predistorter without the even-order terms.

Index Terms—Behavior modeling, digital predistortion, envelope tracking, memory effect, power amplifier.

I. INTRODUCTION

In order to transmit high-data-rate signals to the subscribers, the current and next generation communication systems such as long-term evolution (LTE) and wideband code division multiple access deliver signals with high peak-to-average power ratio (PAPR). Moreover, increasing number of communication standards requires development of the circuit and subsystem capable of multimode/multiband operation. To linearly amplify these rapidly varying signals, the power amplifiers (PAs) of the transmitters operate in a back-off region, leading to a low efficiency. Efficiency enhancement techniques at the back-off power levels have been studied extensively. Among them, the envelope tracking (ET) transmitter depicted in Fig. 1 has attracted a lot of attentions because the PA in the transmitter always operates in the high efficiency region regardless of the input power levels. Theoretically, this transmitter delivers efficiency of 100%. The ET architecture employs a supply modulator to dynamically change the supply voltage of the PA according to the input power level. If the PA is capable of broadband operation, this transmitter can deliver multimode/multiband operation, since the supply modulator is independent of the frequency band, but can be configured to be suitable to the multimode operation and the PA is independent of the operation mode [1]–[6].

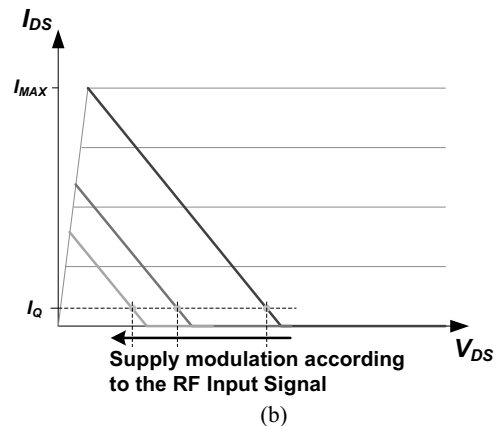
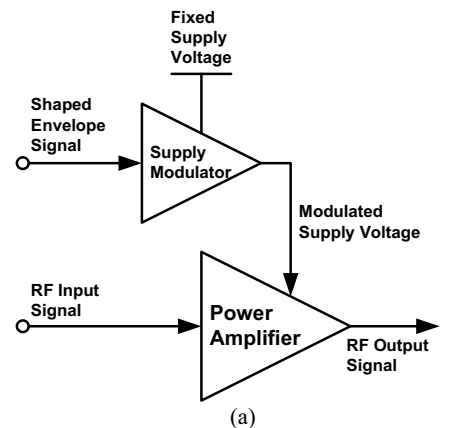

Fig. 1. Block diagram of (a) the envelope tracking power amplifier and (b) load-lines during the tracking operation.

Besides the efficiency issue of the PA, the linearity is an important design parameter because the nonlinear characteristic causes the in-band distortion as well as the spectral regrowth, which should be suppressed to satisfy the linearity requirements of the communication systems. To compensate the nonlinearity of the PA, baseband digital predistortion (DPD) technique is a cost-effective approach. The polynomial-based DPDs have been used extensively for modeling the nonlinear

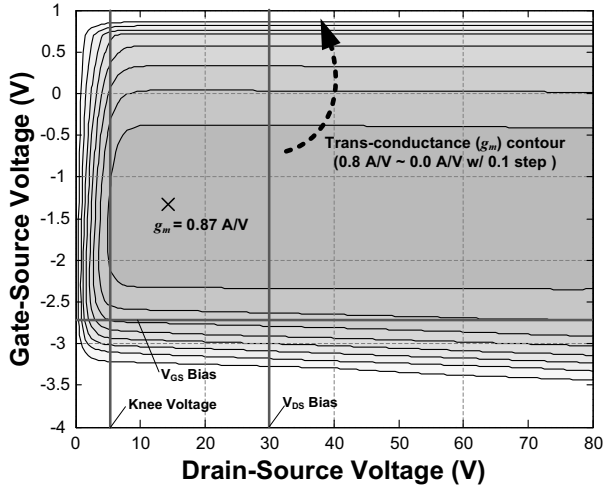

Fig. 2. Simulated g_m characteristic of GaN HEMT CGH40010 transistor.

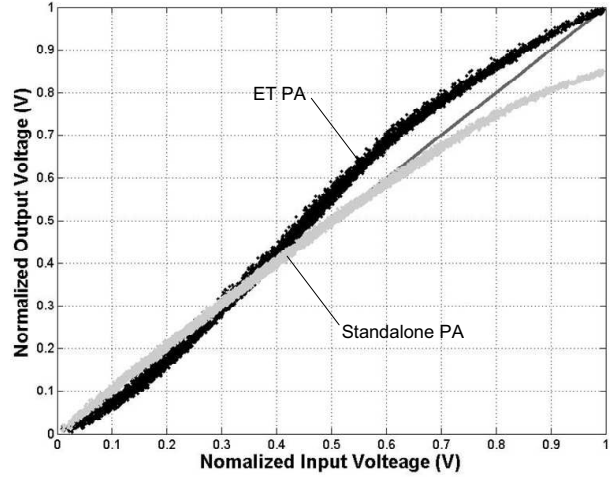

Fig. 3. Measured AM-to-AM characteristics of the standalone and ET PAs.

behavior of the PAs. According to [7] and [8], for a bandpass communication signal, only odd-order nonlinear terms in the PA nonlinearity is sufficient to model the PA and construct the DPD because the even-order terms do not reflect into the first harmonic zone. However, the even-order terms can be omitted due to the fact that the pass band signal is modeled by a polynomial-based model [9]. Some reported papers have verified that better modeling accuracy can be obtained by including the even-order terms in the polynomial-based models for the conventional PAs [9], [10]. Moreover, due to the supply modulated operation of the ET transmitter, the nonlinear behavior of the transmitter is quite different from that of the conventional standalone PAs.

In this paper, we explore the nonlinear behavior of the ET transmitter. Then, to accurately predict and compensate the nonlinear behavior of the transmitter, we employ the even-order terms in the baseband polynomial model. Modeling accuracy and DPD linearization based on the polynomial models with and without the even-order terms are compared. The modeling and linearization performances show that the polynomial model with the even-order terms outperforms the model without the even-order terms.

II. NONLINEAR BEHAVIOR OF ENVELOPE TRACKING POWER AMPLIFIER

Efficiency of an ET transmitter can be improved by modulating the supply voltage as shown in Fig. 1. Although this modulation reduces the dissipated power of the PA in the ET transmitter, it generates a quite different nonlinear behavior, such as amplitude modulation (AM)-to-AM, AM-to-phase modulation (PM), and memory effect, in comparison with a PA with a fixed supply voltage because of the bias dependent trans-conductance (g_m) and parasitic components. Fig. 2 shows the simulated g_m characteristic according to drain-source voltage (V_{DS}) and gate-source voltage (V_{GS}). This characteristic is obtained by Agilent Advanced Design System simulator using CREE gallium nitride (GaN) high

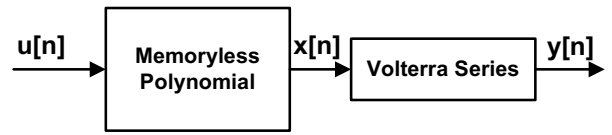

Fig. 4. Block diagram of Enhanced Hammerstein behavior model.

electron mobility transistor (HEMT) CGH40010. Compared to the PA with a fixed V_{DS} , the ET PA has large g_m variation, generating the complex AM-to-AM distortion as shown in Fig. 3.

For a high power amplifier aimed at a wideband signal, the memory effect is one of the most important distortion sources. In general, this effect is reduced by the decoupling capacitors on the bias lines to lower the impedance level at the low frequency region and keep the constant impedance level across the signal bandwidth. However, for the ET transmitter, the decoupling capacitors on the drain bias line cannot be employed. Although the supply modulator acts as a low impedance terminations, it is difficult to maintain the low impedance level of the capacitor across the wide signal band, generating the memory effect problem. Thus, the ET PA has a large and strange dynamic nonlinearity, increasing the dispersion of the AM-to-AM and AM-to-PM characteristics, as shown in Fig. 3. Therefore, to accurately predict and compensate the complex static and dynamic nonlinear behaviors of the ET PA, a precise modeling technique is required.

III. EFFECTS OF EVEN-ORDER TERMS IN ENVELOPE TRACKING POWER AMPLIFIERS

In Section II, the complex nonlinearity of the ET PA is discussed. To accurately compensate and predict this nonlinear behavior, we explore effects of the even-order distortion terms on the polynomial model. In this work, Enhanced Hammerstein structure [10], shown in Fig. 4, is employed to predict and compensate the nonlinearity of the ET PA. For the modeling assessments and DPD experiments, the PA in the ET transmitter is designed using CREE GaN HEMT CGH40010

TABLE I
NMSE AND ACEPR COMPARISONS OF THE STANDALONE AND ET PAs

	NMSE (dB)	ACEPR (dB)
Standalone PA w/o even-order terms	-45.7	-55.3
Standalone PA w/ even-order terms	-46.1	-57.1
ET PA w/o even-order terms	-39.2	-45.9
ET PA w/ even-order terms	-41.1	-49.5

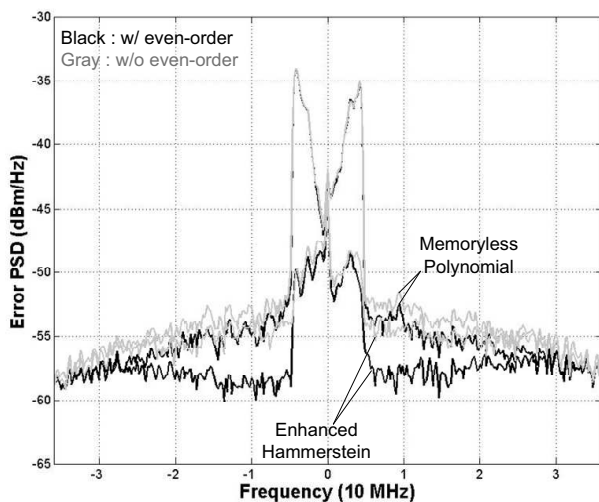

(a)

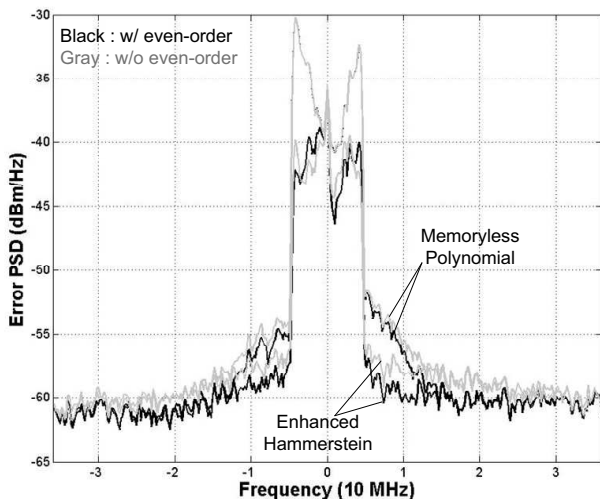

(b)

Fig. 5. Modeling error PSDs of the Enhanced Hammerstein behavior models. (a) ET and (b) standalone PAs.

at 1.8425-GHz, and a hybrid switching amplifier is used for the supply modulator [4], [5]. The LTE signal used has 10-MHz signal bandwidth (BW) and 6.5-dB PAPR.

A. Modeling Assessment

To measure accuracy of the Enhanced Hammerstein model with and without the even-order distortion terms, the normalized mean square error (NMSE) and adjacent channel error

TABLE II
MEASURED ACLR PERFORMANCES WITH AND WITHOUT EVEN-ORDER TERMS AT AN AVERAGE OUTPUT POWER OF 34.8 dBm FOR LTE 1FA SIGNAL

	ACLR (dBc)	
	+/-7.5-MHz	+/-12.5-MHz
ET PA w/o DPD	-29.8/-28.5	-34.4/-34.5
ET PA w/o even-order terms	-43.7/-42.3	-45.1/-45.8
ET PA w/ even-order terms	-47.0/-47.2	-50.1/-50.6

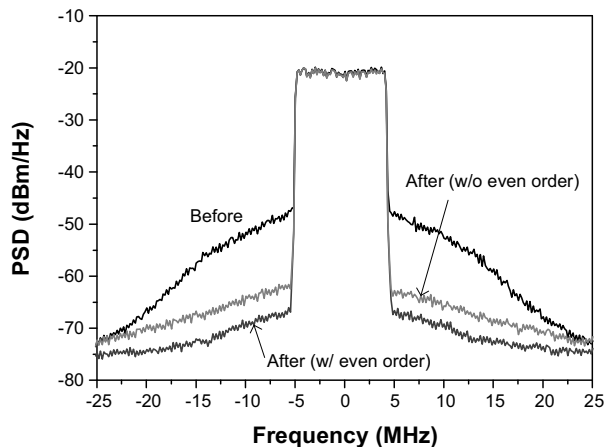

Fig. 6. Measured output PSDs at an average output power of 34.8 dBm.

power ratio (ACEPR) are employed for in-band and out-of-band errors, respectively. Modeling error power spectral density (PSD) is also evaluated. The NMSE and ACEPR performances of the two models are summarized in Table I. The performance difference between the models with and without the even-order terms is rather small for the standalone PA in which the supply voltage is fixed, but is large for the ET PA. Fig. 5 shows the modeling error PSDs of the Enhanced Hammerstein models with and without the even-order terms. The lower modeling errors is achieved from the model with the even order terms for both memoryless and memory predictions and the even order terms are more important for the ET PA. These modeling assessment results show that the even-order terms are essential for the accurate modeling of the ET PA.

B. Digital Predistortion Experimental Results

To validate the better modeling accuracy of the Enhanced Hammerstein structure with the even-order distortion terms, the nonlinearity of the ET PA is compensated using the Enhanced Hammerstein predistorter. An indirect learning method is employed to adjust the coefficients of the predistorter. For the LTE 1FA signal with 10-MHz BW and 6.5-dB PAPR, the ET PA is linearized at an average output power of 34.8 dBm. The linearization results are summarized in Table II and the measured output PSDs are depicted in Fig. 6. The adjacent channel leakage ratios (ACLRs) at an offset of 7.5 MHz and 12.5 MHz are improved by 4.7 dB and 5.0 dB, respectively, by the predistorter with the even-order terms. Fig. 7 shows the

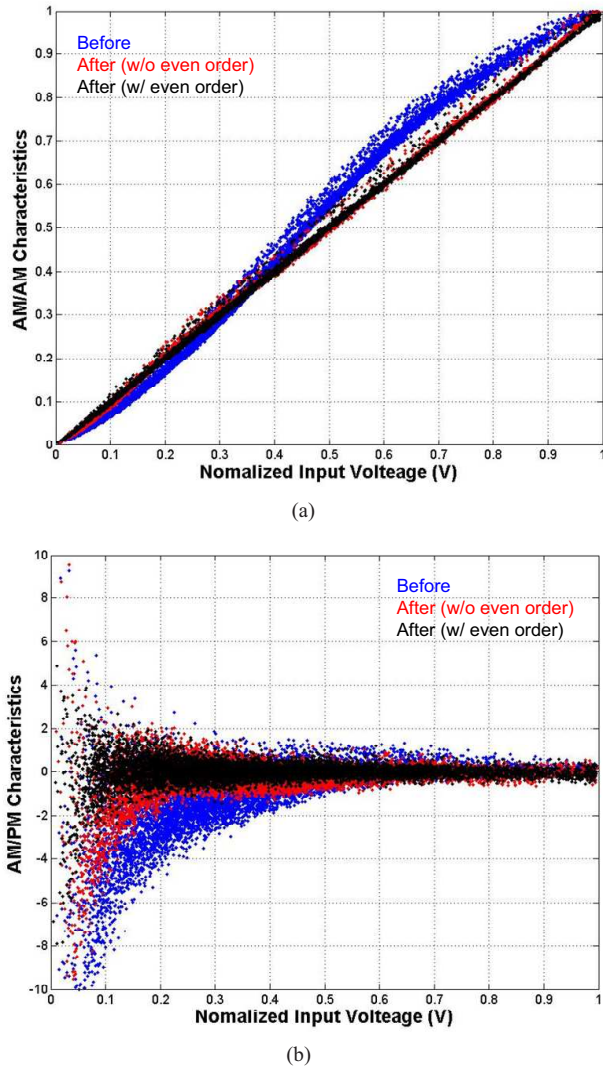

Fig. 7. Measured (a) AM-to-AM and (b) AM-to-PM characteristics.

measured AM-to-AM and AM-to-PM characteristics. For the both predistorters, with and without the even-order nonlinear terms, the static gain and phase deviations are accurately compensated. However, the dispersions on the AM-to-AM and AM-to-PM distortions are better suppressed by the predistorter with the even-order terms. During the construction of memoryless block, the both predistorters have the same polynomial order of 11. For the Volterra series on both predistorters have also the same nonlinear order of 3 and the memory depth of 2. These modeling assessments and DPD experimental results clearly show the importance of the even-order terms for the ET PA, especially for the memory effect.

IV. CONCLUSIONS

The ET transmitters have different nonlinear characteristics from the standalone PA, due to the supply modulated operation for high efficiency. The effects of the even-order nonlinear terms on the behavior model and DPD linearization for the ET transmitters are explored using the Enhanced Hammerstein

structure. By including the even-order terms, the modeling accuracy are significantly improved, especially for memory effect. To demonstrate the improved accuracy for the nonlinear prediction, the indirect learning based Enhanced Hammerstein predistorter is employed for compensating the ET PA. For the LTE signal with 10-MHz BW and 6.5-dB PAPR, the predistorter including the even-order terms delivers a far better linearization result than the predistorter excluding the even-order. These results clearly show the importance of the even-order terms for the ET PA modeling and linearization.

ACKNOWLEDGEMENT

This work was supported by the MKE(The Ministry of Knowledge Economy), Korea, under the ITRC(Information Technology Research Center) support program supervised by the NIPA(National IT Industry Promotion Agency)(NIPA-2011-(C1090-1111-0011)) and WCU(World Class University) program funded by the Ministry of Education, Science and Technology through the National Research Foundation of Korea(R31-10100).

The authors would like to thank CREE Inc., Durham, NC, for providing the GaN HEMT transistors and models used in this work.

REFERENCES

- [1] F. H. Raab, P. Asbeck, S. Cripps, P. B. Kenington, Z. B. Popović, N. Pothecary, J. F. Sevic, and N. O. Sokal "Power amplifiers and transmitters for RF and microwave," *IEEE Trans. Microw. Theory Tech.*, vol. 50, no. 3, pp. 814–826, Mar. 2002.
- [2] J. Choi, D. Kang, D. Kim, J. Park, B. Jin, and B. Kim, "Power amplifiers and transmitters for next generation mobile handset," *J. Semicond. Technol. Sci.*, vol. 9, no. 4, pp. 249–256, Dec. 2009.
- [3] S. C. Cripps, *RF Power Amplifiers for Wireless Communications*. 2nd ed. Norwood, MA: Artech House, 2006.
- [4] D. F. Kimball, J. Jeong, C. Hsia, P. Draxler, S. Lanfranco, W. Nagy, K. Linthicum, L. E. Larson, and P. M. Asbeck, "High-efficiency envelope-tracking W-CDMA base-station amplifier using GaN HFETs," *IEEE Trans. Microw. Theory Tech.*, vol. 54, no. 11, pp. 3848–3856, Nov. 2006.
- [5] J. Choi, D. Kim, D. Kang, and B. Kim, "A polar transmitter with CMOS programmable hysteretic-controlled hybrid switching supply modulator for multi-standard applications," *IEEE Trans. Microw. Theory Tech.*, vol. 57, no. 7, pp. 1675–1686, Jul. 2009.
- [6] A. Zhu, P. J. Draxler, C. Hsia, T. J. Brazil, D. F. Kimball, and P. M. Asbeck, "Digital predistortion for envelope-tracking power amplifiers using decomposed piecewise Volterra series," in *IEEE Trans. Microw. Theory Tech.*, vol. 56, no. 10, pp. 2237–2247, Oct. 2008.
- [7] S. Benedetto and E. Biglieri, *Principles of Digital Transmission with Wireless Applications*. New York: Kluwer, 1999.
- [8] S. P. Stapleton and J. K. Cavers, "A new technique for adaptation of linearizing predistorters," in *Proc. 41st IEEE Veh. Technol. Conf.*, May 1991, pp. 753–758.
- [9] L. Ding and G. T. Zhou, "Effects of even-order nonlinear terms on power amplifier modeling and predistortion linearization," *IEEE Trans. Veh. Technol.*, vol. 53, no. 1, pp. 156–162, Jan. 2004.
- [10] J. Moon and B. Kim, "Enhanced Hammerstein behavioral model for broadband wireless transmitters," *IEEE Trans. Microw. Theory Tech.*, vol. 59, no. 4, pp. 924–933, Apr. 2011.